

FEATURES

- Up to 4 shutter channels
- Automatic travel time measurement through current detection (only possible when using AC powered shutters)
- Possibility of controlling blinds/shutters with 2 or 3 dry contacts*
- Manual output operation with push button and LED status indicator
- Supports KNX Data Secure
- 20 logic functions
- Output timing
- Total data saving on KNX bus failure
- Integrated KNX BCU (TP1-256)
- Dimensions 67 x 90 x 70 mm (4 DIN units)
- DIN rail mounting according to IEC 60715 TH35, with fixing clamp
- Possibility of connecting different phases in adjacent outputs
- Conformity with the CE, UKCA, RCM directives (marks on the right side)

* In case of 3 dry contacts, an individual output on another actuator is required for the stop contact

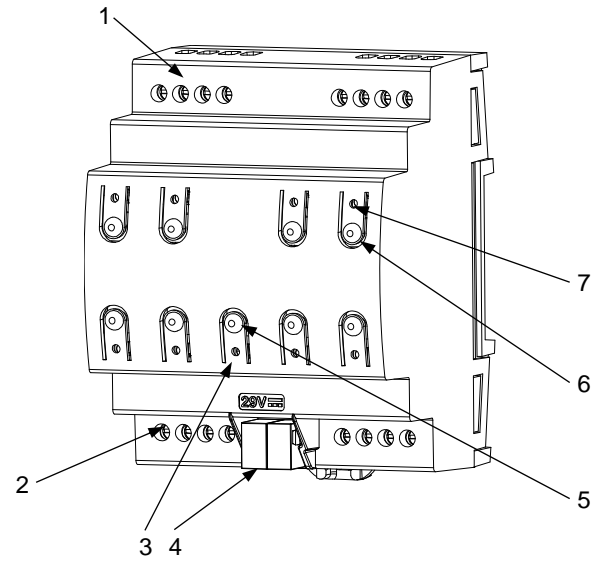

Figure 1: ShutterBOX Drive 4CH

1. Upper outputs	2. Lower outputs	3. Programming/Test LED	4. KNX connector
5. Programming/Test button	6. Output control button	7. Output status LED	

Programming/Test button: short press to set programming mode. If this button is held while plugging the device into the KNX bus, it enters the safe mode. If this button is held for more than 3 seconds, the device enters the test mode. In order to perform a KNX Secure factory reset, while the device is in safe mode, press the button for 10 seconds until the programming LED changes its state.

Programming/Test LED: programming mode indicator (red). When the device enters the safe mode, it blinks (red) every half second. The test mode is indicated by the green color. During the start-up (reset or after KNX bus failure) and if the device is not in safe mode, it starts a blue blinking sequence.

GENERAL SPECIFICATIONS				
CONCEPT		DESCRIPTION		
Type of device		Electric operation control device		
KNX supply	Voltage (typical)		29 VDC SELV	
	Voltage range		21-31 VDC	
	Maximum consumption	Voltage	mA	mW
		29 VDC (typical)	4.0	116
24 VDC ¹	10	240		
Connection type		Typical TP1 bus connector for 0.8 mm Ø rigid cable		
External power supply		Not required		
Operation temperature		0 .. +55 °C		
Storage temperature		-20 .. +55 °C		
Operation humidity		5 .. 95%		
Storage humidity		5 .. 95%		
Complementary characteristics		Class B		
Protection class / Overvoltage category		II / III (4000 V)		
Operation type		Continuous operation		
Device action type		Type 1		
Electrical stress period		Long		
Degree of protection / Pollution degree		IP20 / 2 (clean environment)		
Installation		Independent device to be mounted inside electrical panels with DIN rail (IEC 60715)		
Minimum clearances		Not required		
Response on KNX bus failure		Data saving according to parameterization and relays contacts opening		
Response on KNX bus restart		Data recovery according to parameterization		
Operation indicator		The programming LED indicates programming mode (red) and test mode (green). Each output LED indicates its status		
Weight		279 g		
PCB CTI index		175 V		
Housing material / Ball pressure test temperature		PC FR V0 halogen free / 75 °C (housing) - 125 °C (connectors)		

¹ Maximum consumption in the worst-case scenario (KNX Fan-In model).

OUTPUTS SPECIFICATIONS AND CONNECTIONS	
CONCEPT	DESCRIPTION
Number of outputs	4 shutter channels
Output type / Disconnection type	Potential-free outputs through bistable relays / micro-interruption
Rated current per output	AC 8(4) A @ 250 VAC (2000 VA) DC 5 A @ 30 VDC (150 W)
Maximum load per output	Resistive
	Inductive
Different phases connection	Possibility of connecting different phases
Short-circuit protection	NO
Overload protection	NO
Connection method	Screw terminal block (0.5 Nm max.)
Cable cross-section	0.5-2.5 mm ² (IEC) / 26-12 AWG (UL)
Maximum response time	15 ms
Mechanical lifetime (min. cycles)	1 000 000

WIRING DIAGRAMS

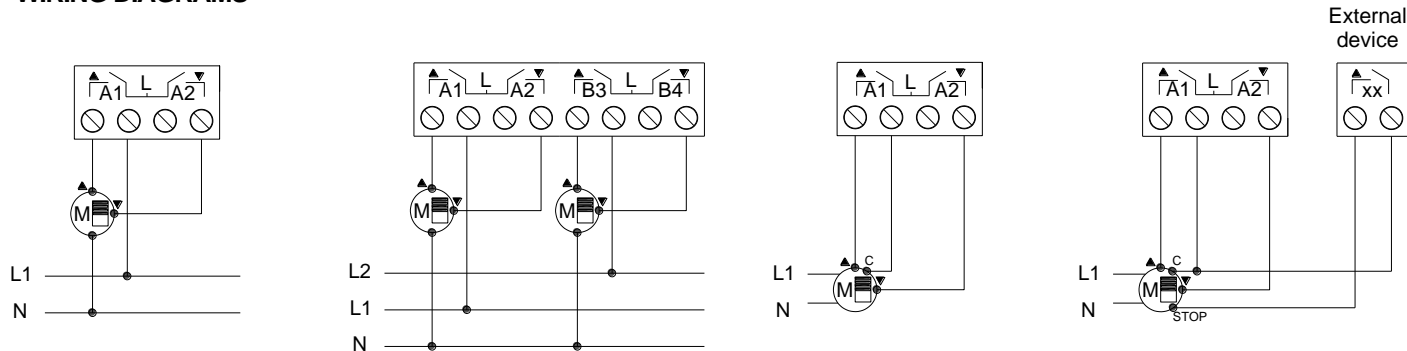
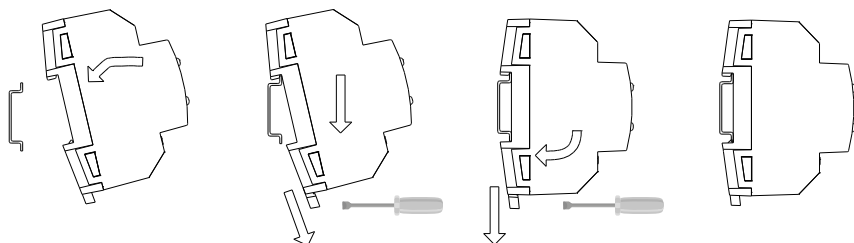

Figure 2: Wiring example (from left to right): one shutter on channel A; two shutters on channels A and B with different phases; one shutter with 2 dry contacts on channel A; one shutter with 3 dry contacts on channel A and on the individual output B3

⚠ In order to ensure the expected status of the relays, please check that the device is connected to the KNX bus before energizing the power circuit.

Attaching ShutterBOX Drive 4CH to DIN rail:



Removing ShutterBOX Drive 4CH from DIN rail:

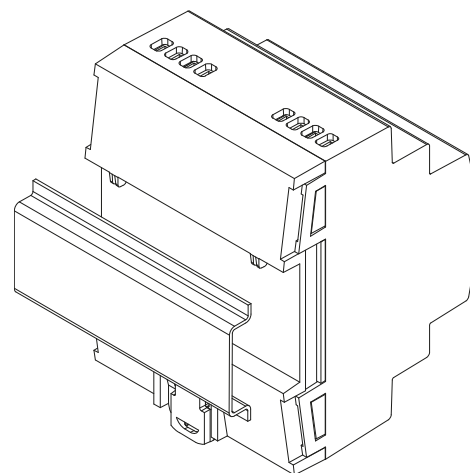
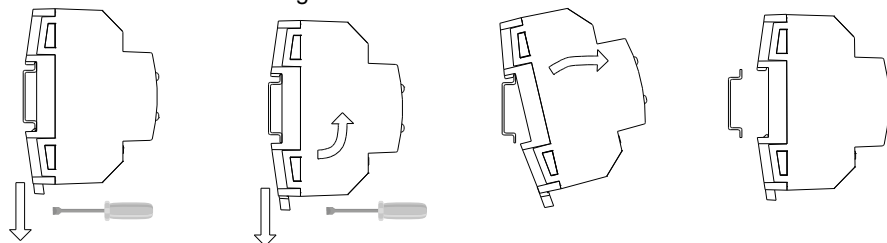

Figure 3: Mounting ShutterBOX Drive 4CH on DIN rail

SAFETY INSTRUCTIONS AND ADDITIONAL NOTES

- Installation should only be performed by qualified professionals according to the laws and regulations applicable in each country.
- Do not connect the mains voltage nor any other external voltage to any point of the KNX bus; it would represent a risk for the entire KNX system. The facility must have enough insulation between the mains (or auxiliary) voltage and the KNX bus or the wires of other accessories, in case of being installed.
- Once the device is installed (in the panel or box), it must not be accessible from outside.
- Keep the device away from water (condensation over the device included) and do not cover it with clothes, paper or any other material while in use.
- The WEEE logo means that this device contains electronic parts and it must be properly disposed of by following the instructions at <https://www.zennio.com/en/legal/weee-regulation>.
- This device contains software subject to specific licences. For details, please refer to <https://zennio.com/licenses>.