

FEATURES

- KNX TP/RF Media Coupler (RF1.R @868.3MHz).
- Internal RF antenna.
- Total data saving on KNX bus failure.
- Integrated KNX BCU.
- Dimensions 39 x 39 x 10.5mm.
- Can be mounted within distribution boxes or wall back boxes.
- Conformity with the CE directives (CE-mark on the rear side).

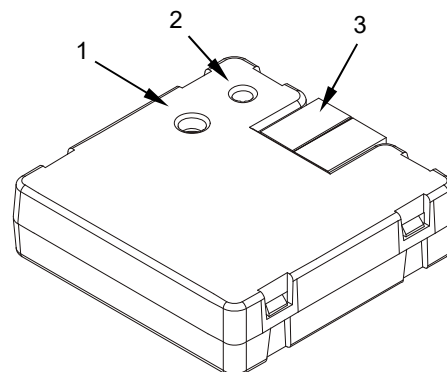

Figure 1: ZMCoup RF 868

1. Programming/Factory reset button	2. Programming/RF traffic LED	3. KNX connector
<p>Programming/Factory reset button: short press to set programming mode. If this button is held while plugging the device into the KNX bus, it enters the safe mode. If the device is already in safe mode and this button is held for more than 10 seconds, a factory reset is performed.</p> <p>Programming/RF traffic LED: programming mode indicator (red). When the device enters the safe mode, it blinks (red) every half second. During the start-up (reset or after KNX bus failure) and if the device is not in safe mode, it emits a red flash. If the device is not in programming or safe mode, it emits a green flash to indicate the reception of a RF frame from its own domain.</p>		

GENERAL SPECIFICATIONS

CONCEPT		DESCRIPTION		
Type of device		Electric operation control device		
KNX supply	Voltage (typical)	29VDC SELV		
	Voltage range	21..31VDC		
	Maximum consumption ²	Voltage	mA	mW
		29VDC (typical)	6.2	179.8
24VDC ¹	10	240		
Connection type		Typical TP1 bus connector for 0.80mm Ø rigid cable		
Communication type		KNX RF Ready (Bi-directional)		
Radio frequency		868.3MHz		
Maximum transmission power		20mW (13dBm)		
External power supply		Not required		
Operation temperature		0°C .. +55°C		
Storage temperature		-20°C .. +55°C		
Operation humidity		5 .. 95%		
Storage humidity		5 .. 95%		
Protection class		III		
Operation type		Continuous operation		
Device action type		Type 1		
Electrical stress period		Long		
Complementary characteristics		Class B		
Degree of protection		IP20, clean environment		
Installation		Independent device to be mounted inside distribution boxes or wall back boxes.		
Minimum clearances		Not required		
RF Range ³		Up to 180m in free-field		
Response on KNX bus failure		Data saving according to parameterization		
Response on KNX bus restart		Data recovery according to parameterization		
Operation indicator		The programming LED indicates programming mode (red). A green flash indicates the reception of a RF frame in its domain.		
Weight		14g		
PCB CTI index		175V		
Housing material		PC FR V0 halogen free		

¹ Maximum consumption in the worst-case scenario (KNX Fan-In model).

² The maximum consumption depends on the transmission power parameterized.

³ The maximum range depends on several factors such as environmental conditions, device orientation, type and thickness of the surrounding materials, etc.

DIMENSIONS (mm)

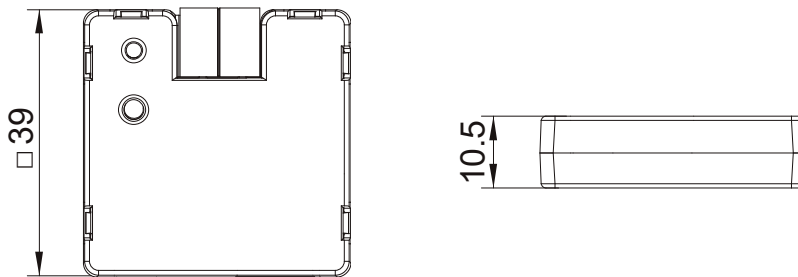

INSTALLATION NOTES

- The maximum range of an RF communication depends largely on the building materials or the environmental phenomena (rain, snow...). There are materials such as reinforced concrete, bricks or metallic surfaces which attenuate the signal more than others like drywalls or wood.
- The RF signal can be reflected by some surfaces (depending on the material, dimensions...), which may affect the transmissions.
- The installation of RF devices near the ground is not recommended.
- RF devices must not be installed inside metallic boxes or cabinets.
- It is recommended that the ZMCoup RF is located approximately in the centre of all the RF devices of its line.
- In order to extend the range of an RF facility, bidirectional devices configured as Domain Retransmitters can be used. However, an excessive use of them may saturate the transmission medium.
- It is recommended to avoid the installation of RF devices near electromagnetic sources (wireless telephones, electronic control gears, microwaves, WiFi routers, Bluetooth devices...)

SAFETY INSTRUCTIONS AND ADDITIONAL NOTES

- Installation should only be performed by qualified professionals according to the laws and regulations applicable in each country.
- Do not connect the mains voltage nor any other external voltage to any point of the KNX bus; it would represent a risk for the entire KNX system. The facility must have enough insulation between the mains (or auxiliary) voltage and the KNX bus or the wires of other accessories, in case of being installed.
- Once the device is installed (in the panel or box), it must not be accessible from outside.
- Keep the device away from water (condensation over the device included) and do not cover it with clothes, paper or any other material while in use.
- The WEEE logo means that this device contains electronic parts and it must be properly disposed of by following the instructions at <http://zennio.com/wEEE-regulation>.
- This device contains software subject to specific licences. For details, please refer to <http://zennio.com/licenses>.