

FEATURES

- Up to 4 shutter channels.
- Manual output operation with push button and LED status indicator.
- Logical functions included.
- Output timing facilities.
- Total data saving on KNX bus failure.
- Dimensions 67 x 90 x 79mm (4.5 DIN units).
- DIN rail unit assembly (EN 50022), through pressure.
- No external power supply required other than the bus.
- Integrated KNX BCU.
- Possibility to connect different phases in adjoining shutter channel outputs.
- Conformity with the CE directives (CE-mark on the right side).

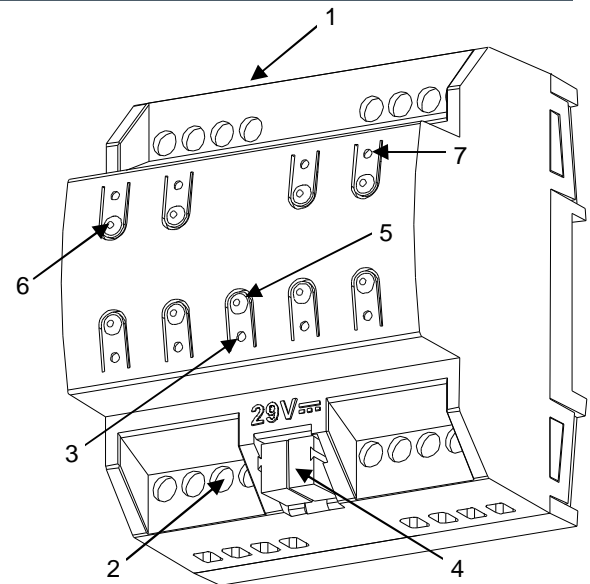

Figure 1. MAXinBOX SHUTTER 4CH

1. Upper outputs	2. Lower output screws	3. Programming/Test LED	4. KNX connector
5. Programming/Test button	6. Output control button	7. Output status indicator LED	

Programming/test button: short button press to set programming mode. If this button is held while plugging the device into the KNX bus, it enters in safe mode. If this button is held during 3 seconds, the device enters in test mode.

Programming/Test LED: programming mode indicator (red). When the device enters in safe mode, it blinks (red) every half second. The manual mode is indicated by the green color. During start-up (reset or KNX bus failure) and if the device is not in safe mode, it makes a blue flashing.

GENERAL SPECIFICATIONS				
CONCEPT		DESCRIPTION		
Type of device		Electric operation control device		
KNX supply	Voltage (typical)		29VDC SELV	
	Voltage range		21...31V DC	
	Maximum consumption	Voltage	mA	mW
		29VDC (typical)	5.8	168.2
24VDC ⁽¹⁾	10	240		
Connection type		Typical bus connector TP1 for rigid cable 0.80mm Ø		
External power supply		Not required		
Operation temperature		from 0°C to +55°C		
Storage temperature		from -20°C to +70°C		
Operation humidity		5 to 95% RH (no condensation)		
Storage humidity		5 to 95% RH (no condensation)		
Complementary characteristics		Class B		
Protection class		II		
Operation type		Continuous operation		
Device action type		Type 1		
Electrical stress period		Long		
Degree of protection		IP20, clean environment		
Installation		Independent device to be mounted inside electrical panels with DIN rail (EN 50022).		
Minimum clearances		Not required.		
Response on KNX bus failure		Data saving according to parameterization and open relays		
Response on KNX bus restart		Data recovery according to parameterization		
Operation indication		Programming LED indicates programming mode (red) and test mode (green). Output status LED indicators reflect current output state.		
Weight		253g		
PCB CTI index		175V		
Housing material		PC FR V0 halogen free		

⁽¹⁾ Maximum consumption in the worst case scenario (KNX Fan-In model)

OUTPUTS SPECIFICATIONS AND CONNECTIONS		
Contact type	Potential free outputs through bistable relays	
Disconnection type	Micro-disconnection	
Rated current by output	\sim 10A (5) * 250VAC (2500VA) \equiv 10A * 30VDC (300W)	
Outputs per common	1 common per shutter channel	
Different phases connection	Possibility to connect different phases in adjoining shutter channel outputs (see "wiring and assembly diagrams" section)	
Maximum power per output	Resistive	2500W
	Inductive	1250VA
Connection type	Screw terminal block	
Cable type	Stranded or solid wire.	
Maximum response time	50 ms	
Lifetime	Mechanical (min.)	1 million cycles (180cpm)
	Electrical (min.)	50.000 cycles (6cpm with resistive load)

WIRING AND ASSEMBLY DIAGRAMS

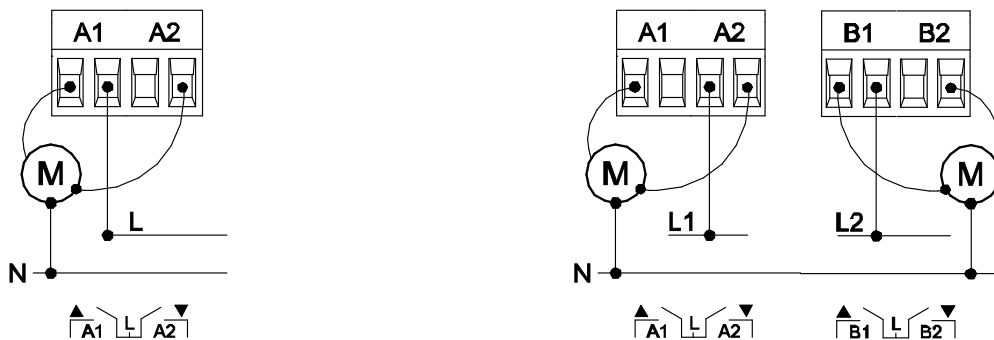

⚠ In order to ensure the expected status of the relays, please check that the device is connected to the KNX bus before energizing the power circuit.

Figure 2. Wiring examples (from left to right): channel A and channel A and B with different phases

Attaching MAXinBOX SHUTTER 4CH to DIN rail:

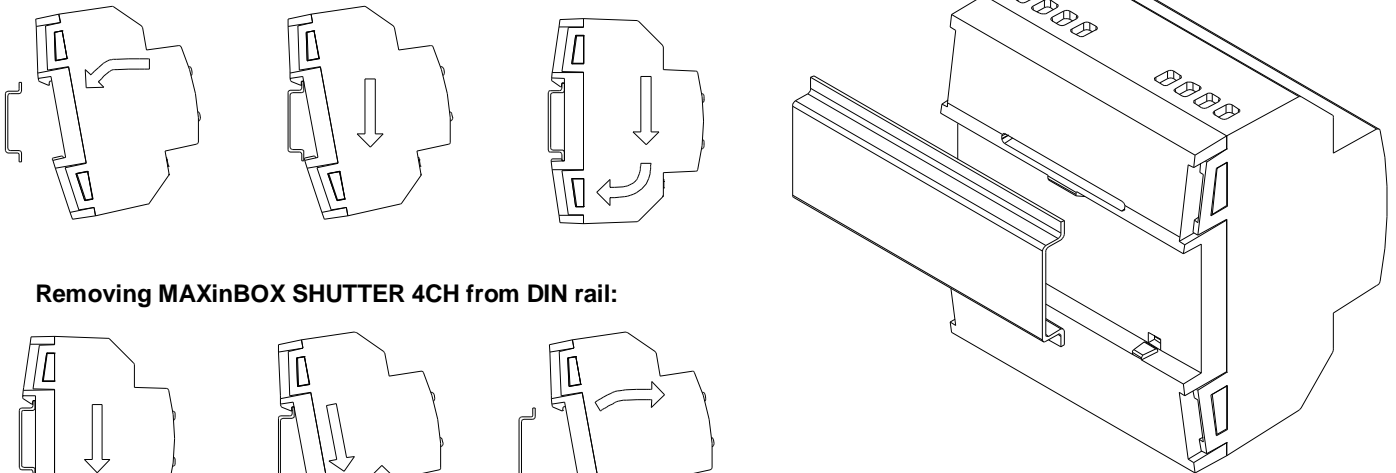

Figure 3. Mounting MAXinBOX SHUTTER 4CH on a DIN rail

⚠ SAFETY INSTRUCTIONS

- Installation should only be performed by qualified professionals according to the laws and regulations applicable in each country.
- Do not connect the mains voltage nor any other external voltage to any point of the KNX bus; it would represent a risk for the entire KNX system. The facility must have enough insulation between the mains (or auxiliary) voltage and the KNX bus or the wires of other accessories, in case of being installed.
- Once the device is installed (in the panel or box), it must not be accessible from outside.
- Keep the device away from water and do not cover it with clothes, paper or any other material while in use.
- The WEEE logo means that this device contains electronic parts and it must be properly disposed of by following the instructions at <http://zennio.com/wEEE-regulation>.

